

# **Interior FRT Wood**

## **References to ICC Building Codes**

### **Table of Contents**

International Building Code (IBC)	1
International Residential Code (IRC)	6

2009 Edition, published by the International Code Council

## Uses

1. Noncombustible Type Construction - Untreated wood is not permitted. Fire-retardant-treated (FRT) wood may be used in specific instances.

## Criteria

- Fire-retardant-treated wood is any wood product which, when impregnated with chemicals by a pressure process or other means during manufacture, shall have, when tested in accordance with ASTM E 84 or UL 723, a listed flame spread index of 25 or less and show no evidence of significant progressive combustion when the test is continued for an additional 20-minute period. Additionally, the flame front shall not progress more than 10.5 feet (3200 mm) beyond the centerline of the burners at any time during the test. {Ref.: IBC Section 2303.2}
- All fire-retardant-treated lumber and wood structural panel products shall be properly labeled with the identifying mark of an approved testing agency, identification of the treating manufacturer, name of fire-retardant treatment, wood species treated, flame spread and smoke developed index, drying method used after treatment and conformance with appropriate standards as required by Section 2303.2.4. For fire-retardant-treated wood exposed to weather, damp or wet locations, include the words “No increase in the listed classification when subjected to the Standard Rain Test” (ASTM D 2898). {Ref.: IBC Section 2303.2.6}
- Design values for untreated lumber and wood structural panels shall be adjusted for strength for fire-retardant-treated wood. Design value adjustments shall be based on an approved investigation method that considers the effect of the anticipated temperature and humidity that the fire-retardant wood will be exposed to and the type of treatment and re-drying procedures used. {Ref.: IBC Section 2303.2.2}
  1. Fire-retardant-treated wood structural panels (softwood plywood) shall meet the requirements of ASTM D 5516 and ASTM D 6305 where applicable. Each manufacturer shall publish the allowable maximum loads and spans for floor and roof sheathing for its treatment. {Ref. IBC Section 2303.2.5.1}

2. Fire-retardant-treated lumber shall meet the requirements of ASTM D 5664 for each species of wood treated. Each manufacturer shall publish the modification factors for service at temperature of not less than 80° F and for roof framing. The roof framing modification factors shall take in consideration the climatological location. {Ref. IBC Section 2303.2.5.2}

- Interior applications of fire-retardant treated wood shall be marked “Type A” and not have a moisture content greater than 28 percent when tested using ASTM D 3201 procedures at 92 percent relative humidity. {Ref.: IBC Section 2303.2.7}
- Prior to use fire-retardant-treated wood shall be dried to a moisture content of 19 percent or less for lumber and 15 percent or less for wood structural panels. Wood kiln dried after treatment (KDAT) shall not exceed the kiln or drying temperatures used previously to dry the lumber and plywood. {Ref.: IBC Section 2303.2.8}
- Buildings of Type I and II construction have limited applications for fire-retardant-treated wood as required by IBC Section 603.1. {Ref.: IBC Section 2303.2.9}
- Fasteners for fire-retardant-treated wood shall be in accordance with manufacturer’s recommendations. In the absence of manufacturer’s recommendations, Section 2303.9.5.3 shall apply – hot-dipped zinc-coated galvanized steel, stainless steel, silicon bronze or copper. {Ref.: IBC Section 2303.9.5.4}

Not all FRT wood products perform alike.  
See strength properties of Dricon® FRT wood on page 6.

# INTERNATIONAL BUILDING CODE (cont.)

## Applications

### Type I and Type II Construction

Fire-retardant-treated wood is permitted in Type I and II construction in the following applications:

1. Non-load bearing partitions rated 2 hours or less. {Ref.: IBC Section 603.1, exception 25.1}
2. Non-load bearing exterior walls where no fire rating is required. {Ref.: IBC Section 603.1, exception 25.2; see also IBC Table 602}

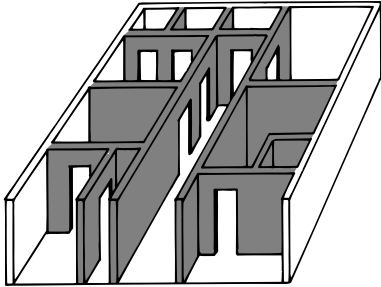

Note: Shaded areas indicate permitted uses of FRT wood.

3. Roof construction as permitted in Table 601, Note b. {Ref.: IBC Section 603.1, exception 25.3}
4. Partitions separating the interior areas of stores, offices or similar spaces occupied by a single tenant may be constructed of fire-retardant treated wood, 1 hour fire-rated construction or of wood panels or similar light construction up to 6 feet in height provided the partitions do not form an enclosed corridor with an occupant load of 30 or more. {Ref.: IBC Section 603.1, Item 10}
5. Materials in concealed spaces are permitted in accordance with Section 717.5. {Ref.: IBC Section 603.1, Item 23}
6. Materials exposed within plenums complying with Section 602 of the International Mechanical Code (IMC). {Ref.: IBC Section 603.1, Item 24}

### Type III Construction

Fire-retardant-treated wood complying with Section 2303.2 shall be permitted for use as a substitute for noncombustible materials in exterior wall assemblies with a 2-hour fire resistance rating or less. {Ref.: IBC Section 602.3}

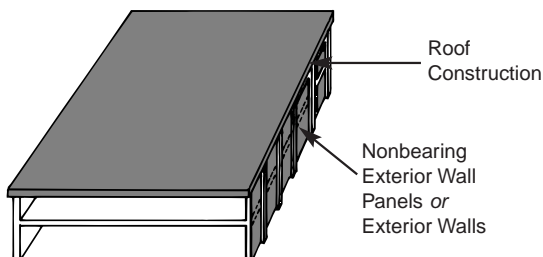

### Type IV Construction (Heavy timber, HT)

Fire-retardant-treated wood complying with Section 2303.2 shall be permitted for use as a substitute for noncombustible materials in exterior wall assemblies with a 2-hour fire resistance rating or less. {Ref.: IBC Section 602.4}

### Type V Construction

Structural elements, exterior walls and interior walls may be constructed of any materials permitted by the code, both combustible and noncombustible. {Ref.: IBC Section 602.5}

### Exterior Walls and Roofs

Exterior nonbearing walls or wall panels and gable ends of roofs may be of noncombustible materials or fire-retardant-treated wood when the horizontal fire separation distance is more than 30 feet for all construction types and group designations. For horizontal fire separation distances less than 30 feet, refer to Table 602 for the fire-resistance rating requirements of exterior walls based on the type of construction and group designation. {Ref.: IBC Table 601, footnote f}

### Roof Construction

Roof construction, including supporting beams and joists, may be constructed using fire-retardant-treated wood as follows:

1. Except in Factory-Industrial (F-1), Hazardous (H), Mercantile (M) and Moderate-Hazard Storage (S-1) occupancies, fire protection of structural members shall not be required, including protection of roof framing and decking where every part of the roof construction is 20 feet or more above any floor immediately below. Fire-retardant-treated wood members shall be allowed to be used for such unprotected members. {Ref. IBC Table 601, footnote b}
2. In Type I and II construction, fire-retardant-treated wood is allowed in buildings including girders and trusses as part of the roof construction when the building is:
  - a) Two stories or less in height. {Ref.: IBC Table 601 footnote b}
  - b) Type II construction over two stories; or {Ref.: IBC Table 601 footnote b}
  - c) Type I construction over two stories in height and the vertical distance from the upper floor to the roof is 20 feet or more. {Ref.: IBC Table 601 footnote b}

**Parapets and Fire Wall Extensions**

A. Parapets shall be provided on buildings and have the same fire-resistance rating as that required for the supporting wall, and on any side adjacent to a roof surface, and shall have a noncombustible face for the uppermost 18 inches including counter flashing and coping materials. The height of the parapet shall not be less than 30 inches above the point where the roof surface and wall intersect except that in Type III, IV and V construction of Residential Groups R-2 and R-3 as applicable per IBC Section 101.2, a parapet is not required on an exterior building wall when the wall is terminated at the roof sheathing or deck that is constructed of fire-retardant treated wood for a distance of 4 feet continuously on both sides of the exterior wall intersection and the roof covering is Class C minimum. {Ref.: IBC Section 705.11.5.1}

Note for IBC Residential Group R-3: Detached one and two family dwellings (duplexes) and multiple single-family dwellings (town houses) separated a 2-hour fire-rated wall with a separate means of egress and not more than 3 stories in height shall comply with the International Residential Code (IRC). {Ref.: IBC Section 101.2}

B. Fire walls shall extend from the foundation to a termination point at least 30 inches above both adjacent roofs, except that in buildings of Types III, IV and V construction, walls shall be permitted to terminate at the underside of fire-retardant-treated wood within 4 feet of each side of the fire wall where both buildings are provided with not less than a Class B roof covering. {IBC Section 706.6, exception 4.3}

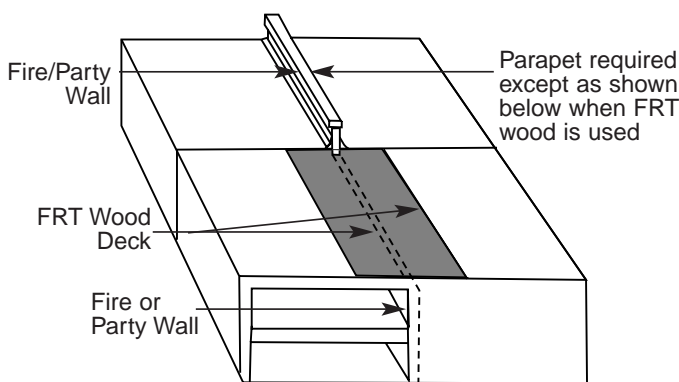

**Miscellaneous Roof Structures**

Towers, spires, domes and cupolas shall be not be less than the fire-resistance rating required for the building where attached and shall not be used for habitation or storage, except that:

- Any tower, spire, steeple or other roof structure not used for habitation or storage shall be unlimited in height if of noncombustible materials and shall not extend more than 20 feet above the allowable height if of combustible materials. {Ref.: IBC Section 504.3}
- Any tower, spire, dome or cupola greater than 85 feet in height above the roof or greater than 200 square feet at any horizontal section, or which are used for any purpose other than a belfry or architectural embellishment, shall be constructed of and supported by Type I and II construction. {Ref.: IBC Section 1509.5}
- Any tower, spire, dome or cupola greater than 60 feet in height above the roof or greater than 200 square feet at any horizontal section, or which are used for any purpose other than a belfry or architectural embellishment, shall be constructed of and supported by noncombustible materials. Enclosed towers and spires shall have exterior walls and roofs of the same construction as required for the building walls and roofs. {Ref.: IBC Section 1509.5.1}
- Enclosed towers and spires such as church spires and other towers and spires of a similar nature shall have exterior walls and roof coverings as required for the main building to which they are attached. {Ref.: Section 1509.5.2}
- Penthouses complying with applicable provisions shall be considered as a portion of the story below, and shall be constructed with walls, floors and roof as required for the building. {Ref.: IBC Section 1509.2; see exceptions at 1509.2.4}

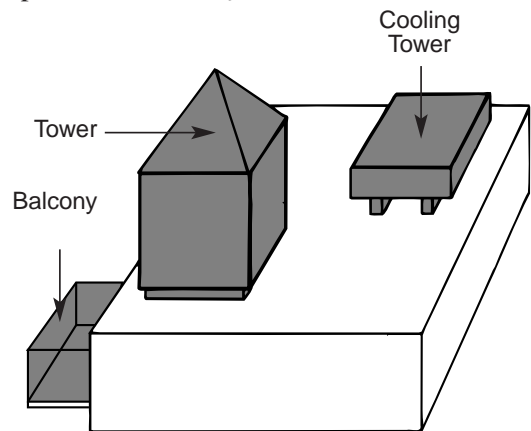

**Cooling Towers**

Non-load bearing framing of cooling towers greater than 250 square feet in base area or greater than 15 feet high and that do not exceed one-third of the supporting roof area in buildings greater than 50 feet in height may be of noncombustible construction. {Ref.: IBC Section 1509.4}

# INTERNATIONAL BUILDING CODE (cont.)

## Balconies and Similar Projections

Balconies and similar projections of floors may be constructed of fire-retardant treated wood in accordance with IBC Chapter 14. {Ref.: IBC Section 603.1, Note 12} The aggregate length of balconies and similar projections on each floor cannot exceed 50% of the building perimeter unless the balcony areas are protected by fire sprinklers. {Ref.: IBC Section 1406.3}

1. In Type I and II construction, balconies, porches, decks and exterior stairways not used as required exits on buildings that are not more than 3 stories in height are permitted to be constructed of fire-retardant-treated wood. {Ref.: IBC Section 1406.3, exception 1}
2. In Type III, IV and V construction, balconies and similar appendages that are not protected by a sprinkler system may be constructed of fire-retardant-treated wood. {Ref.: IBC Section 1406.3, exception 3}

## Bay Windows and Oriel Windows

Bay windows and oriel windows in Type I, II, III and IV construction on buildings that are not more than 3 stories in height are permitted to be constructed using fire-retardant treated wood. {Ref.: IBC Section 1406.4}

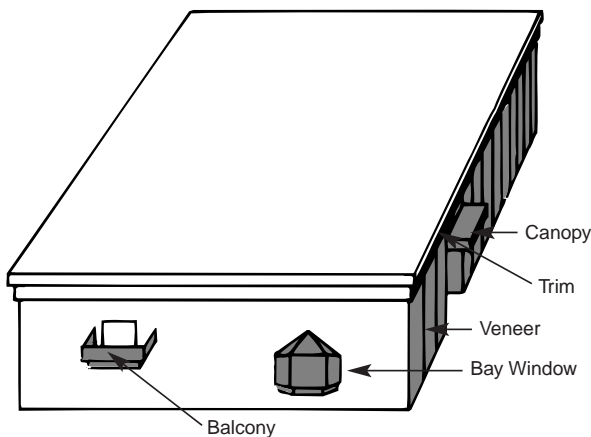

## Awnings and Canopies

- Awnings may have frames of noncombustible material, fire-retardant-treated wood, wood of Type IV size, or 1-hour construction with combustible or noncombustible covers and shall be either, fixed, retractable, folding or collapsible. {Ref.: IBC Section 3105.3}
- Canopies shall be constructed of a rigid framework with an approved covering that is flame resistant in accordance with NFPA 701 or has a flame spread index not greater than 25 when tested in accordance with ASTM E 84 or UL 723. {Ref.: IBC Section 3105.4}

- Permanent canopies are permitted to extend over adjacent open spaces provided: 1) the canopy and its supports are of noncombustible material, fire-retardant-treated wood, Type IV construction or of 1-hour fire-resistance-rated construction; 2) any canopy covering, other than textiles, shall have a flame spread index not greater than 25 when tested in accordance with ASTM E 84 or UL 723 in the form intended for use; 3) the canopy shall have at least one long side open; 4) the canopy width does not exceed 15 feet; and 5) the fire rating of exterior walls is not reduced. {Ref.: IBC Appendix D102.2.8}

## Service Stations

Canopies under which fuels are dispensed shall have a clear, unobstructed height of not less than 13 feet 6 inches (4115 mm) to the lowest projecting element in the vehicle drive-through area. Canopies and their supports over pumps shall be of noncombustible materials, fire-retardant-treated wood complying with Chapter 23, wood of Type IV sizes or of construction providing 1-hour fire resistance. {Ref.: IBC Section 406.5.3}

## Kiosks in Covered Malls

Kiosks and similar structures (temporary or permanent) are permitted within a mall if constructed of fire-retardant-treated wood complying with Section 2303.2. Kiosks cannot exceed 300 square feet (28 m<sup>2</sup>) in area, must be provided with approved fire suppression and detection devices and the horizontal separation between kiosks or kiosk groupings and other structures must be at least 20 feet (6096 mm). {Ref.: IBC Section 402.11}

## Interior Finishes

Interior wall and ceiling finishes shall be classified by their flame spread and smoke-developed indexes in accordance with ASTM E 84. Such interior finish materials shall be grouped in the following classes in accordance with their flame spread and smoke-developed index as follows {Ref.: IBC Section 803.1}

Class A: flame spread 0-25; smoke-developed 0-450

Class B: flame spread 26-75; smoke-developed 0-450

Class C: flame spread 76-200; smoke developed 0-450

Except materials, other than textiles, tested in accordance with Section 803.1.2.

- Interior walls and ceiling finish shall have a flame spread index no greater than that specified in Table 803.5 for the occupancy group and location designated. {Ref.: IBC Section 803.9}

- Where walls and ceilings are required to be fire-rated or of noncombustible construction, the interior finish material shall be applied directly to such construction or to furring strips not more than 1-3/4 inches from such surfaces. {Ref.: IBC Section 803.11.1}
- Any hangers and assembly members of such dropped ceilings that are set-out (furred) below the main ceiling line shall be of noncombustible materials, except that in Type III and V construction, fire-retardant-treated wood is permitted. {Ref. IBC Section 803.11.2}

### Permanent Platforms

In Type I, II, and IV construction, permanent platforms are permitted to be constructed of fire-retardant-treated wood where the platforms are not more than 30 inches above the main floor, are not more than one-third of the room floor area and are not more than 3,000 square feet in area. Where the space beneath the permanent platform is used for storage or any

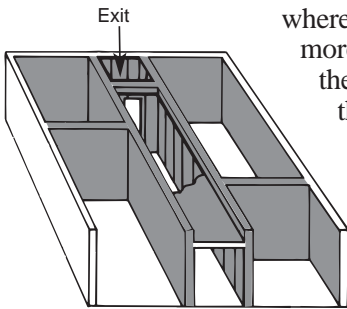

purpose other than equipment, wiring or plumbing, the floor construction shall not be less than 1-hour fire-resistant construction. Where the space beneath the permanent platform is used only for equipment, wiring or plumbing, the underside of the permanent platform need not be protected. Permanent platforms shall be constructed of materials as required for the type of construction of the building in which the permanent platform is located. {Ref.: IBC Section 410.4}

### Combustibles in Concealed Spaces

Combustibles shall not be permitted in concealed spaces of buildings of Type I or II construction, except:

1. Fire-retardant-treated wood complying with Section 603, Item 8. {Ref.: IBC Section 717.5, Item 1}
2. Combustible materials complying with Section 602 of the International Mechanical Code (IMC). {Ref.: IBC 717.5, Item 2}
3. Class A interior finish materials. {Ref.: IBC Section 717.5, Item 3}

Note: Dricon® fire retardant treated wood is listed as “Interior Type A, high temperature (HT)” in accordance with AWPA UCFA for lumber and plywood. {Ref.: See Fire Performance section of this Application Guide}

Common features of both:

1. 12" concrete block for bearing walls
2. 2' x 4' mineral fiber acoustic tile in exposed grid suspension system for ceilings
3. 4" concrete slab on grade for floor
4. Same floor-to-finished-ceiling height

## Design Considerations

### Savings Using Fire Retardant Treated Wood Trusses in Lieu of Steel Bar Joists.

Two roof assemblies for the same basic one-story light commercial building are compared; both should be classified as Type II construction according to the provisions of the International Building Code (IBC). {Ref.: IBC Sections 602.1 and 602.2, Table 601}

#### System A — Roof assembly with steel bar joists

1. Roofing membrane: 4-ply built-up, gravel surfaced
2. Insulation: 2-1/2" urethane with R=20
3. Metal roof deck: 1-1/2" deep, 22 gauge, galvanized
4. Steel bar joists: 24LH04 at 5'-0" on centers

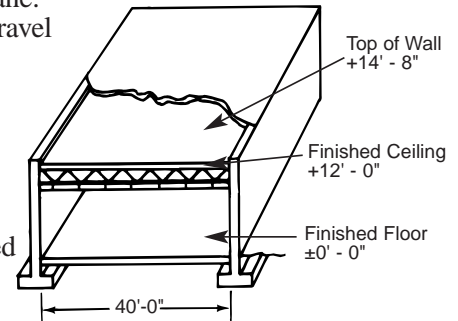

#### System B — Roof assembly with FRT wood trusses

1. Roofing: Inorganic asphalt shingles over No. 15 felt underlayment
2. One layer of 1/2" thick FRT plywood sheathing
3. Light wood trusses of fire retardant treated lumber at 2'-0" on centers
4. Foil faced glass fiber insulation between trusses: 6" thick with R=19

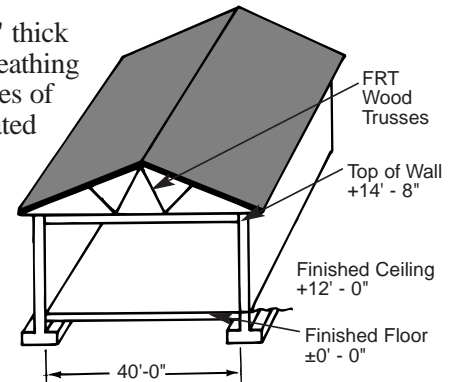

Average cost of assembly B is

about 5 percent less than assembly A, which does not include further savings for reduction in height of exterior walls while maintaining same finished-floor-to-ceiling height.

#### Advantages of System A over System B:

1. Venting of ceiling plenum not required
2. Extent of any required fire rated partition for tenant separation is less above finished ceiling

#### Advantages of System B over System A:

1. Lower cost of roof assembly
2. Exterior walls 2 feet lower
3. Positive roof drainage, less possibility of leakage
4. Less expensive roof drainage system
5. HVAC ducts may be run within truss space

# INTERNATIONAL RESIDENTIAL CODE

2009 Edition, published by the International Code Council

## Uses

1. Combustible Type Construction: Untreated wood is permitted. Fire-retardant-treated (FRT) wood may be used in specific instances.

## Criteria

- The provisions for fire-retardant-treated wood in the International Residential Code (IRC) specifically apply to the design and construction of roof-ceiling systems as required by Section R801. {Ref.: IRC Section R801.1.3}
- All fire-retardant-treated lumber and wood structural panel products shall be properly identified by a grade mark of an approved agency complying with DOC PS 20. A certificate of inspection issued by a lumber grading or inspection agency shall be accepted in lieu of a grade mark. {Ref.: IRC Section R802.1}
- Fire-retardant-treated wood is any wood product which, when impregnated with chemicals by a pressure process or other means during manufacture, shall have, when tested in accordance with ASTM E 84, a listed flame spread index of 25 or less and shows no evidence of significant progressive combustion when the test is continued for an additional 20-minute period. In addition, the flame front shall not progress more than 10.5 feet (3200 mm) beyond the centerline of the burners at any time during the test. {Ref.: IRC Section R802.1.3}
- Fire-retardant-treated lumber and wood structural panels shall be properly labeled to include the identification mark of an approved agency, treating manufacturer, name of fire-retardant treatment, wood species, flame spread and smoke developed rating, and method of drying after treatment, and must conform to any ASTM standards required. Fire-retardant-treated wood exposed to weather, damp or wet locations shall state “No increase in the listed classification when subjected to the Standard Rain Test” (ASTM D 2898). {Ref.: IRC Section R802.1.3.4}
- Design values for untreated lumber and wood structural panels shall be adjusted for strength taking into consideration the effect of the anticipated temperature and humidity exposure, method of treatment and re-drying procedures in accordance with ASTM D 5516 and ASTM D 5564. {Ref.: IRC Section R802.1.3.5}
- The effect of treatment, re-drying method after treatment, exposure to high temperature and high humidity exposure on the flexure properties of fire-retardant-treated softwood plywood shall be determined in accordance with ASTM D 5516. Wood structural panels shall be adjusted for maximum loads and spans, or both for untreated plywood design values in accordance with ASTM D 6305. Manufacturers must publish the allowable maximum loads and spans for service as floor and roof sheathing for their treatment. {Ref.: IRC Section R802.1.3.5.1}
- The effect of treatment, re-drying method after treatment, exposure to high temperature and high humidity exposure on the allowable design properties of fire-retardant-treated lumber shall be determined in accordance with ASTM D 5664. Each manufacturer shall publish the modification factors for service at temperatures of not less than 80° F (26° C) and for roof framing. The modification factors for roof framing shall take in consideration the climatic location. {Ref.: IRC Section R802.1.3.5.2}
- Any fire-retardant-treated wood products exposed to the weather, damp or wet locations shall be identified as “Exterior” and “No increase in the listed classification when subjected to Standard Rain Test,” indicating the listed flame spread classification has not increased when subjected to ASTM D 2898. {Ref.: IRC Section R802.1.3.6}
- Interior applications of fire-retardant treated wood shall be marked “Type A” and not have a moisture content greater than 28 percent at 92 percent relative humidity when tested using ASTM D 3201 procedures. {Ref.: IRC Section R802.1.3.7}
- Prior to use fire-retardant-treated wood shall be dried to a moisture content of 19 percent or less for lumber and 15 percent or less for wood structural panels. Wood kiln dried after treatment (KDAT) shall not exceed the kiln or drying temperatures used previously to dry the lumber and plywood. {Ref.: IRC Section R802.1.3.8}
- Fasteners for fire-retardant treated wood used in interior locations shall be in accordance with the manufacturer’s recommendations. In the absence of the manufacturer’s recommendations, Section R317.3.3 for exterior and wet or damp locations shall apply – hot-dipped zinc-coated galvanized steel, stainless steel, silicon bronze or copper, and for fasteners other than nails and timber rivets, mechanically deposited zinc-coated steel with coating weights in accordance with ASTM B 695, Class 55 minimum. {Ref.: IRC Section 317.3.4}

## Applications

### Dwelling Unit Separation

- A. Parapets constructed in accordance with Section R302.2.3 shall be constructed for townhouses as an extension of exterior walls or common walls. Where roof surfaces adjacent to the wall or walls are at the same elevation, the parapet shall extend not less than 30 inches (762 mm) above the roof surfaces. Where roof surfaces adjacent to the wall or walls are at different elevations and the higher roof is not more than 30 inches (762 mm) above the lower roof, the parapet shall extend not less than 30 inches (762 mm) above the lower roof surface.

A parapet is not required when the roof is covered with a minimum class C roof covering, and the roof decking or sheathing is of noncombustible materials or approved fire-retardant-treated wood for a distance of 4 feet (1219 mm) on each side of the wall or walls, or one layer of 5/8-inch (15.9 mm) Type X gypsum board is installed directly beneath the roof decking or sheathing, supported by a minimum of nominal 2-inch (51 mm) ledgers attached to the sides of the roof framing members, for a minimum distance of 4 feet (1219 mm) on each side of the wall or walls. {Ref.: IRC Section R302.2.2}

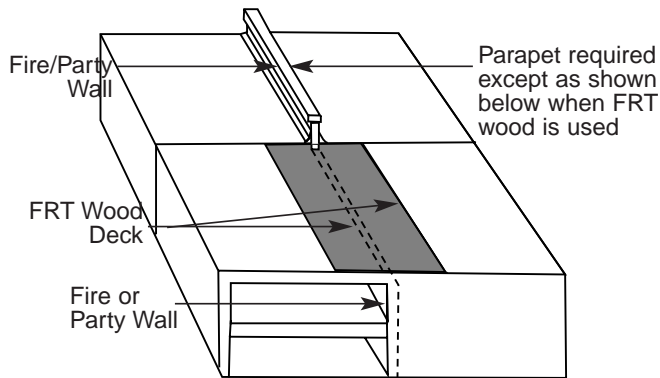

- B. Walls that separate dwelling units in two-family dwellings (duplexes) shall be separated from each other by wall and/or floor assemblies having not less than 1-hour fire-resistance rating tested in accordance with ASTM E 119. Fire-resistance-rated floor-ceiling and wall assemblies shall extend to and be tight against the exterior wall, and wall assemblies shall extend to the underside of the roof sheathing except that a fire resistance rating of 1/2 hour shall be permitted in buildings equipped throughout with an automatic sprinkler system installed in accordance with NFPA 13. {Ref.: IRC Section R302.2.3}
- When floor assemblies are required to be fire resistance rated by Section R317.1, the supporting construction of such assemblies shall have an equal or greater fire-resistive rating. {Ref.: IRC Section R302.3.1}
  - Fire-retardant-treated plywood equivalent to 1/2 inch gypsum board may be used to construct the access doors of folding pull down stairs installed in the garage ceiling assembly upon approval by the local building official or authority having jurisdiction.
  - Fire-retardant-treated plywood equivalent to 1/2 inch gypsum board applied to the garage side may be used upon approval by the building official or authority having jurisdiction.

### Roof-mounted collectors

The roof shall be constructed to support the loads imposed by roof-mounted solar collectors. Roof-mounted solar collectors that serve as a roof covering shall conform to the requirements for roof coverings in Chapter 9 of the IRC code. Where mounted on or above the roof coverings, the collectors and supporting structure shall be constructed of noncombustible materials or fire-retardant-treated wood equivalent to that required for the roof construction. {Ref. IRC Section M2301.2.2}