

# **Interior FRT Wood**

## **References of Previous Model Building Codes**

### **Table of Contents**

SBBCI Standard Building Code	1
ICBO Uniform Building Code	3
BOCA National Building Code	5

# 10-SBBCI STANDARD BUILDING CODE

1994 Edition, published by Southern Building Code Congress International, Inc.

## Uses

1. Noncombustible types of construction: Untreated wood is not permitted. Fire retardant treated wood may be used in specific instances.
2. All types of construction: Fire retardant treated wood or noncombustible materials required in specific instances.

## Criteria

- Flame spread classification shall be 25 or less and show no evidence of significant progressive combustion for a period of 30 minutes, and the flame front shall not progress more than 10.5 feet beyond the center line of the burners at any time when tested in accordance with ASTM E 84 (Section 202).
- All fire retardant treated wood products shall bear identification showing surface burning characteristics, issued by an approved agency having a re-examination service (Section 2301.8.2).
- When fire retardant treated wood products are to be exposed to weather, they shall be further identified as Exterior Type, indicating that there is no increase in listed fire classification when subjected to ASTM D 2898 (Section 2301.8.3).
- Where experience has demonstrated a specific need for use of material of low hygroscopicity, fire retardant treated wood shall be identified as Type A (Section 2301.8.4).
- Allowable unit stresses for fire retardant treated wood shall be developed from an approved method of investigation (Section 2301.8.1).
- Subsequent to treatment, fire retardant treated lumber and plywood shall be dried to a moisture content of 19 percent or less for lumber and 15 percent or less for plywood. Identification mark shall show method of drying after treatment (Section 2301.8.5).

## Applications

### Exterior Walls and Roofs

#### Construction Type I, Type II, and Type IV:

- Fire retardant treated wood may be used for roof construction for buildings two stories in height in any group of occupancy (Note e to Table 600).

- Exterior nonbearing walls or panels and gable ends of roofs may be of noncombustible materials or of fire retardant treated wood when horizontal separation is more than 30 feet (Note k to Table 600).

*Note: Shaded areas indicate permitted uses of FRT wood.*

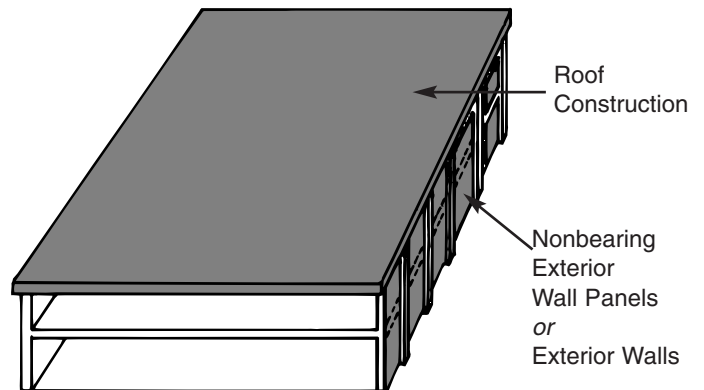

### Townhouse Fire Separation

Walls separating townhouses shall have a parapet not less than 18 inches above the roof line, or, when terminated at the underside of the roof sheathing, the roof sheathing shall be of noncombustible material or fire retardant treated wood; or 5/8 inch thick Type X gypsum board shall be attached to roof decking for a distance of 4 feet minimum on each side of wall (Section 704.4.1 and 704.4.2).

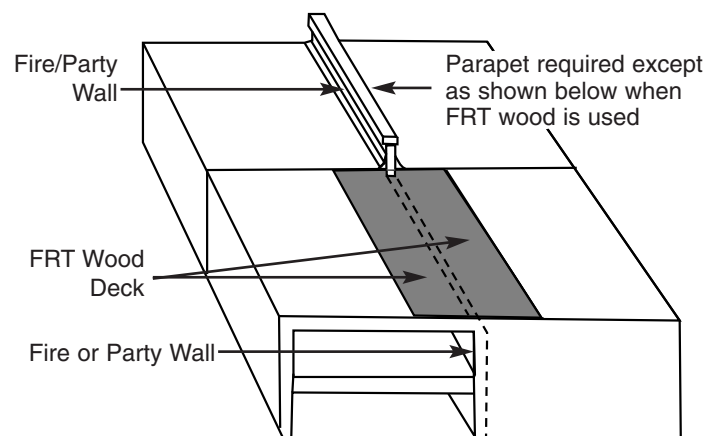

### Fire Wall Extensions

Fire walls shall extend not less than 3 feet above the roof, except fire walls need not extend above the roof in Types III, V and VI construction when the roof is constructed of fire retardant treated wood for a distance of 4 feet minimum on each side of the wall (Section 704.5.1.1).

**2Partitions**

- Nonbearing partitions in Type I and Type II construction shall be constructed of noncombustible materials, except that fire retardant treated wood may be used for framing members in such partitions (Section 609.2.1).

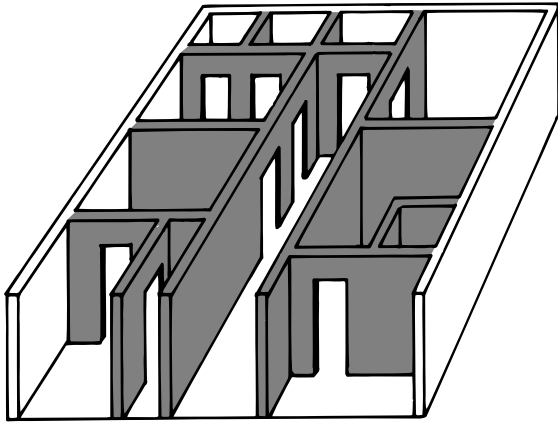

*Note:* Partitions for Group I Restrained Occupancy in Type I and Type II construction shall be of noncombustible materials (Section 704.2.2.1.2).

- Partitions in Type IV construction shall be constructed of noncombustible materials, except that framing members of fire retardant treated wood may be used (Section 609.2.3).

**Exterior Veneer**

Height of wood veneer, when of exterior type fire retardant treated wood, may be increased to four stories in height. Untreated wood veneer is limited to two stories (Section 1403.6.8.1).

**Architectural Trim**

All architectural trim, such as cornices, attached to exterior walls of buildings located in fire districts shall be constructed of noncombustible materials or of fire retardant treated wood only (Section F 102.2.7).

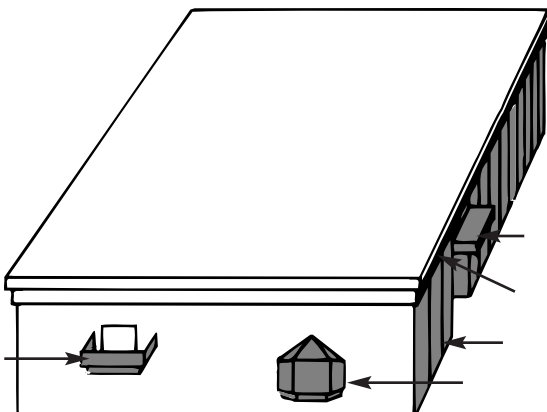

**Balconies and Bay Windows**

Balconies not used as required exits and bay windows shall be of the same type of construction as buildings they are attached to, except that exterior fire retardant treated wood is permitted in buildings three stories or less for Type I and Type II exterior walls (Section 1404.2).

**Canopies**

Canopies attached to buildings when located in fire districts, or when less than thirty feet from an interior lot line or another structure, shall be constructed of noncombustible materials, or of fire retardant treated wood, or of wood of Type III-Heavy Timber sizes, or of one-hour fire resistant construction (Section 3106.2 and Section F 102.2.8).

**Interior Finish**

- The use of a surface finish of paper, or a material of no greater fire hazard than paper, is not prohibited. However, such finish must not exceed 1/28 inch in thickness and must be applied directly to a noncombustible base or a substrate of fire retardant treated wood conforming to the requirements of Section 2301.0 (Section 803.8.2).

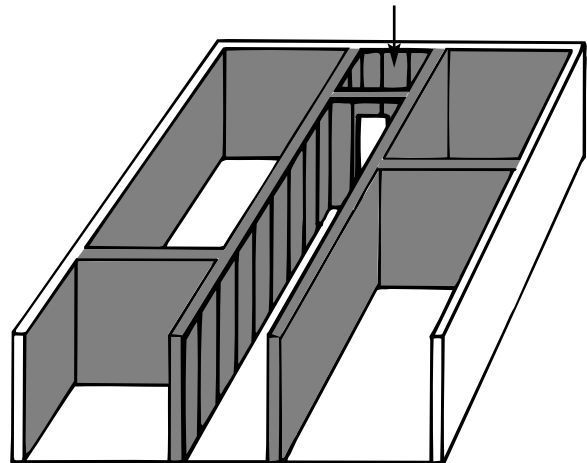

- Where walls and ceilings are required to be fire resistance rated, or of noncombustible materials, or of fire retardant treated wood, and where walls are set out or ceilings dropped more than 1-3/4 inches, Class A finish materials shall be used except where finish materials are protected on both sides by automatic fire extinguishing systems or are attached to a noncombustible or fire retardant treated wood backing. Hangers and assembly members of dropped ceilings which are below the main ceiling line shall be of noncombustible materials or of fire retardant treated wood (Section 803.8.2).

# 10-ICBO UNIFORM BUILDING CODE

1994 Edition, published by International Conference of Building Officials

## Uses

1. Noncombustible types of construction: Untreated wood is not permitted. Fire retardant treated wood may be used in specific instances as defined in the code.

## Criteria

Section 207-F contains a definition of fire retardant treated wood, requiring that:

- Fire retardant treated lumber and plywood, when tested in accordance with U.B.C. Standard 8-1 for a period of 30 minutes, shall have a flame spread rating of not over 25 and show no evidence of progressive combustion. In addition, the flame front shall not progress more than 10.5 feet beyond the center line of the burner.
- Fire retardant treated wood which may be exposed to the weather shall maintain the fire retardant classification when tested in accordance with the rain and weathering tests of U.B.C. Standard 23-5 and shall be identified as Exterior Type.
- Fire retardant treated wood, where exposed to high humidity conditions, shall be subjected to the hygroscopic test and identified as Interior Type A in accordance with U.B.C. Standard 23-5.
- Fire retardant treated wood shall bear identification showing the fire performance rating thereof, issued by an approved agency having a service for inspection at the factory.
- Fire retardant treated wood shall be dried following treatment to a maximum moisture content of 19 percent or less for solid-sawn lumber and 15 percent or less for plywood (Section 2303.3).
- Adjustment of allowable stresses for fire retardant treated wood shall be made in accordance with provisions of Section 2304.3.

## Applications

### Partitions

#### Construction Type I

- Walls and permanent partitions shall be of noncombustible materials except that nonbearing partitions of one-hour or two-hour fire resistive construction which are not part of a shaft enclosure may have fire retardant treated wood within assembly (Section 602.1 and Table 6-A).

*Note: Shaded areas indicate permitted uses of FRT wood.*

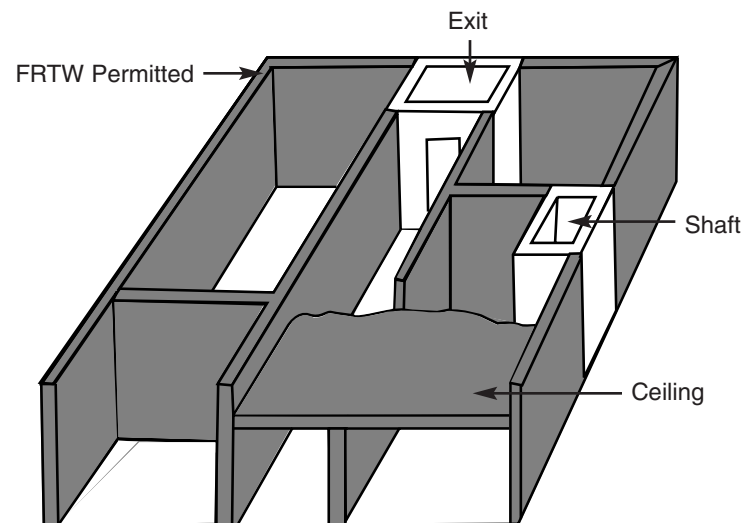

#### Construction Type II

- Walls and permanent partitions shall be of noncombustible materials for Type II -Fire Resistive, except that nonbearing partitions of one-hour or two-hour fire resistive construction which are not part of a shaft enclosure may have fire retardant treated wood within the assembly (Section 603.1 and Table 6-A).
- Walls and permanent partitions shall be of noncombustible materials for Type II -One Hour, except that nonbearing partitions may use fire retardant treated wood within the assembly, provided fire resistance rating requirements are maintained (Section 603.1 and Table 6-A).

### Special Provisions

- Interior nonload-bearing partitions dividing portions of stores, offices or similar places occupied by one tenant only and which do not establish a corridor serving an occupant load that would require it to be of fire-resistive construction may be constructed of noncombustible materials, fire retardant treated wood, or be of one-hour fire-resistive construction (Section 601.5.2.1).

- Interior nonload-bearing partitions within individual dwelling units in apartment houses and guest rooms or suites in hotels, when such are separated from each other and from corridors by not less than one-hour fire-resistive construction, may be constructed of noncombustible materials or fire retardant treated wood in buildings of any type of construction (Section 601.5.2.2).

### **Exterior Walls**

#### **Construction Type III and Type IV**

Exterior walls shall be of noncombustible materials, except that framing of fire retardant treated wood may be used within the assembly when Table 5-A allows a fire resistive rating of two hours or less, provided the required fire resistance rating is maintained and the exposed outer and inner faces of such walls are noncombustible (Section 503.4.3).

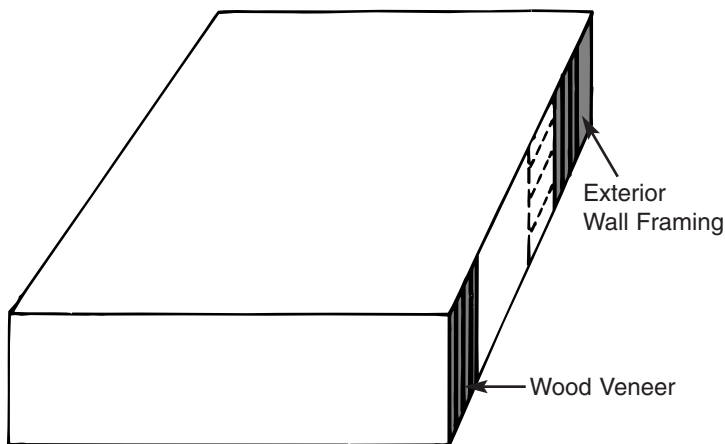

#### **Exterior Wood Veneer**

Untreated wood veneer may extend to a height of 15 feet above grade. When fire retardant treated wood suitable for exterior exposure is used, such height may be increased to 35 feet (Section 601.5.4).

#### **Service Stations**

Marine or motor vehicle service stations, including canopies and supports over pumps, shall be of noncombustible materials, fire retardant treated wood, or of one-hour fire resistance rated construction (Section 311.2.3.2).

### **Interior Finish**

- Where ceilings are dropped more than 1-3/4 inches, hangers and assembly members of such dropped ceilings shall be of noncombustible materials, except that, in Type III and Type V construction, fire retardant treated wood may be used (Section 803).

# 10-BOCA NATIONAL BUILDING CODE

1993 Edition, published by Building Officials and Code Administrators International, Inc.

## Uses

1. Noncombustible types of construction: Untreated wood is not permitted. Fire retardant treated wood may be used in specific instances.
2. Combustible types of construction: Untreated wood is permitted. In specific instances the use of fire retardant treated wood will offer cost advantages or ease limitations imposed.

## Criteria

Section 2310.0 requires that:

- Fire retardant treated wood, where permitted in Type 1 and Type 2 construction, shall not be utilized in load-bearing walls or in assemblies with a required fire resistance rating of more than one hour.
- Fire retardant treated wood, when tested in accordance with ASTM E 84, shall have a flame spread rating of not greater than 25 without evidence of significant progressive combustion when the test is continued for a period of 30 minutes, and the flame front shall not progress more than 10.5 feet beyond the centerline of the burner.
- Fire retardant treated wood shall be dried to a moisture content of 19 percent or less for lumber and 15 percent or less for plywood before use.
- Design values for untreated lumber shall be adjusted for fire retardant treated lumber based on an approved method of investigation.
- Fire retardant treated wood shall bear the identification of an approved testing or inspection agency.
- Fire retardant treated wood, when exposed to the weather, shall be further identified to indicate that there is no increase in listed flame spread after weathering in accordance with ASTM D 2898.
- Fire retardant treated wood subjected to high-humidity conditions shall be identified to indicate that the treated wood has a moisture content of not over 28 percent when tested in accordance with ASTM D 3201.

## Applications

### Walls and Partitions in Type 1 and Type 2 Construction - Noncombustible

Walls and partitions shall be constructed of approved noncombustible materials and protected to afford the fire resistance rating required, except that fire retardant treated wood may be used in:

*Note: Shaded areas indicate permitted uses of FRT wood.*

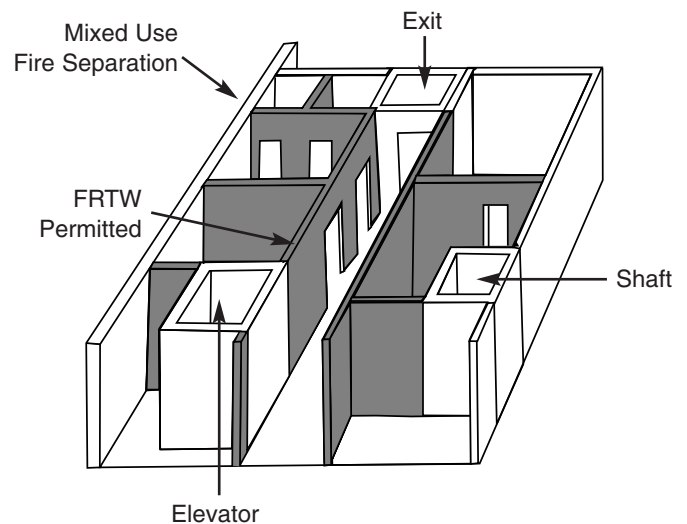

1. Fire separation assemblies other than fire enclosures for exits, shafts, elevator hoistways, and for mixed use separations where the required fire resistance rating is one hour or less (Table 602 and note d).
2. Fire partitions for exit access corridors and tenant space separations (Table 602 and note d).
3. Dwelling unit separations (Table 602 and note d).
4. Nonbearing partitions (Table 602 and note d).
5. Interior partitions: In structures of Type 1 and Types 2A and 2B, except in Occupancy Groups I and R, partitions of single thickness constructed of fire retardant treated wood may be used to subdivide a space, provided that:
  - The area subdivided does not exceed 7,500 square feet between fire separation assemblies or fire walls, and such partitions do not establish a corridor serving an occupant load of 30 or more in areas occupied by a single tenant (Section 603.2).
  - When untreated wood is used, the area subdivided shall not exceed 5,000 square feet.

### 6Kiosk in Covered Malls

Combustible kiosks in covered malls are not permitted unless constructed of fire retardant treated wood throughout (Section 402.15).

### Roofs in Type 1 and Type 2 Construction - Noncombustible

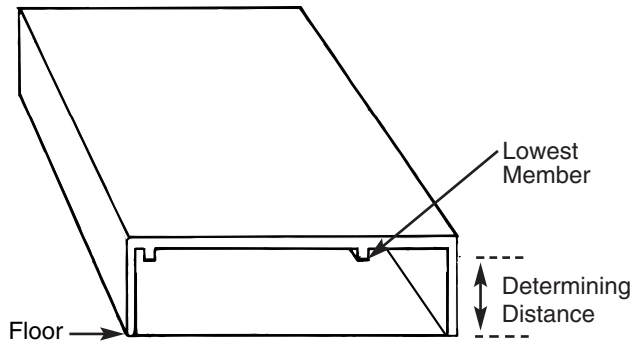

Permitted uses of fire retardant treated wood for roofs in Type 1 and Type 2 construction are contingent on the distance between the lowest part of structural framework of the roof and the floor immediately below. When such distance is:

- 15 feet or less: fire retardant treated wood is permitted in Type 2 construction; not permitted in Type 1 construction (Table 602).
- More than 15 feet but less than 20 feet: fire retardant treated wood is permitted in Type 1 and Type 2 construction (Table 602).
- 20 feet or more: omission of all fire protection of the structural members is permitted (Section 914.3). Roofs shall be constructed of noncombustible materials or of fire retardant treated wood, without a specified fire resistance rating (Table 602 and Section 714.4).

### Roof Deck at Fire Walls in Residential Occupancies

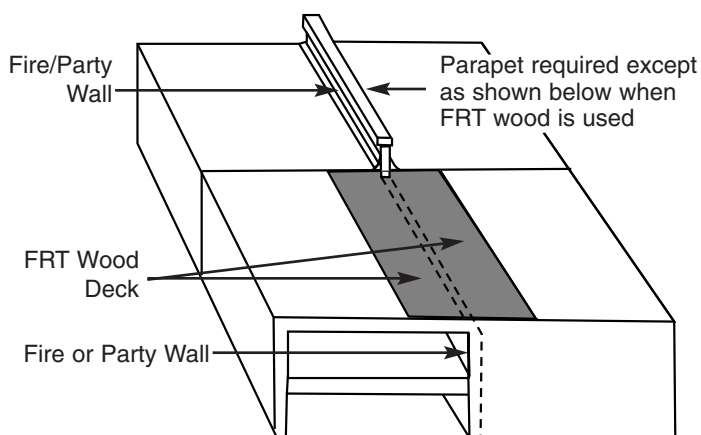

Fire and party walls may be continuous from foundation to underside of the roof deck, provided that:

Roof sheathing or deck shall be constructed of approved noncombustible materials or of fire retardant treated wood for a distance of four feet on either side of the wall (Section 707.5.2).

*Note:* This eliminates the need for coping on top of the wall and flashing and counterflashing at the roof level as well as the cost of the additional wall construction.

### Exterior Trim

Combustible exterior trim, when not of fire retardant treated wood complying with Section 2310.0 for exterior installation, shall not exceed 10 percent of an exterior wall surface area where the fire separation distance is 5 feet or less (Section 1406.2.2).

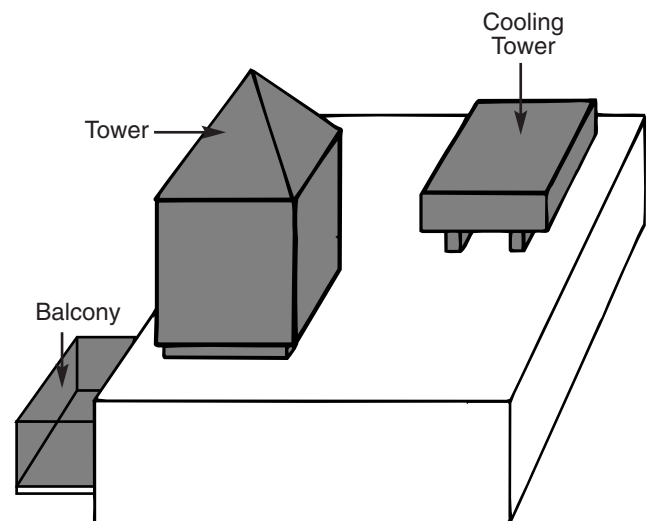

### Balconies and Similar Appendages

All balconies, porches, decks, and supplemental exterior stairways attached to buildings of Types 3, 4, and 5 shall be of fire retardant treated wood or, if of combustible construction, shall afford the fire resistance rating required by Table 602 (Section 1406.4).

### Cooling Towers

Cooling towers erected on roofs of buildings when the base of the tower is more than 55 feet above grade plane shall be constructed of noncombustible materials or of fire retardant treated wood (Section 1510.8).

# 10-BOCA NATIONAL BUILDING CODE CONT.

## Miscellaneous Roof Structures

Towers, spires, dormers or cupolas, when their height exceeds 85 feet above grade plane, or when their area at any horizontal section exceeds 200 square feet, or when used for any purpose other than architectural embellishment, shall be of Type 1 or Type 2 construction, or of fire retardant treated wood (Section 1510.9).

## Interior Finish and Trim

- The use of a surface finish of paper, or a material of no greater fire hazard than paper, shall not be prohibited.

However, such finish must not exceed 1/28 inch in thickness and must be applied directly to a noncombustible base or a substrate of fire retardant treated wood conforming to the requirements of Section 2310.0 (Section 803.1.1).

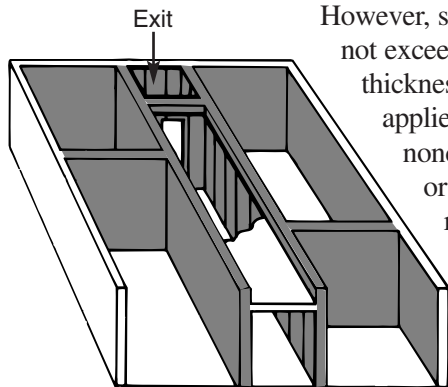

- Where the interior finish is set out or dropped distances greater than 1-3/4 inches, only material of which both faces qualify as Class I shall be used, except that Class II or III materials are permitted in lieu of Class I when attached to backing complying with Section 804.3 (Section 804.2.2, Exception 2).
- The backing for Class II and Class III finish materials less than 1/4 inch thick shall be noncombustible or of fire retardant treated wood complying with requirements of Section 2310.0 (Section 804.3).

## Design Considerations

### Savings Using Fire Retardant Treated Wood Trusses in Lieu of Steel Bar Joists

Two roof assemblies for the same basic one story light commercial building are compared; both should be classified as Type 2C construction under provisions of BOCA National Building Code.

Common features of both:

- 12" concrete block for bearing walls
- 2' x 4' mineral fiber acoustic tile in exposed grid suspension system for ceilings
- 4" concrete slab on grade for floor
- Same floor-to-finished-ceiling height

### System A — Roof assembly with steel bar joists

- Roofing membrane: 4-ply built-up, gravel surfaced
- Insulation: 2-1/2" urethane with R=20

### System A

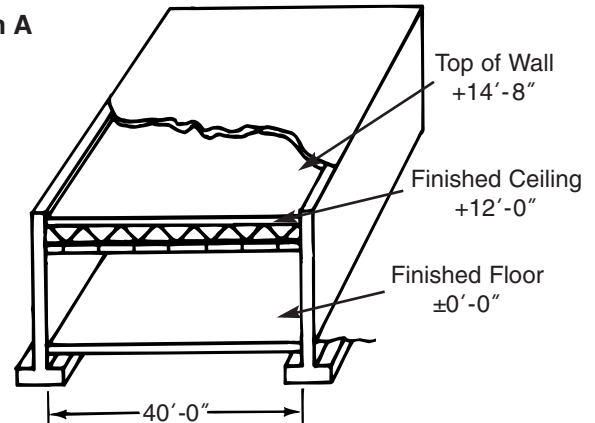

- Metal roof deck: 1-1/2" deep, 22 gauge, galvanized
- Steel bar joists: 24LH04 at 5'-0" on centers

### System B — Roof assembly with FRT wood trusses

- Roofing: Inorganic asphalt shingles over No. 15 felt underlayment
- One layer of 1/2" thick FRT plywood sheathing
- Light wood trusses of fire retardant treated lumber at 2'-0" on centers
- Foil faced glass fiber insulation between trusses: 6" thick with R=19

Average cost of assembly B is about 5 percent less than assembly A, which does not include further savings for reduction in height of exterior walls while maintaining same finished-floor-to-ceiling height.

### System B

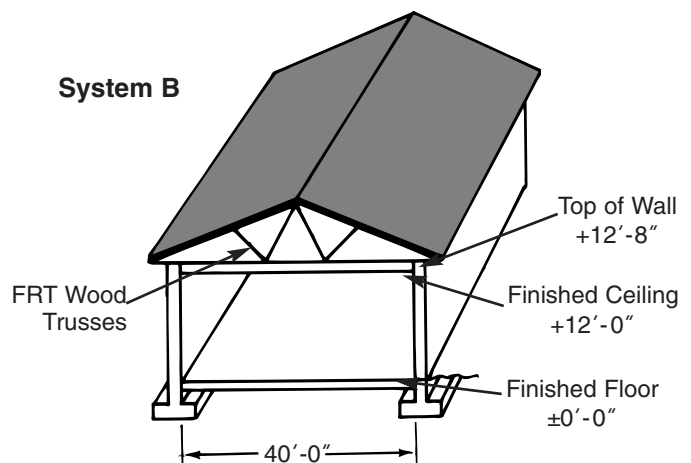

### Advantages of System A over System B:

- Venting of ceiling plenum not required
- Extent of any required fire rated partition for tenant separation is less above finished ceiling

### Advantages of System B over System A:

- Lower cost of roof assembly
- Exterior walls 2 feet lower
- Positive roof drainage, less possibility of leakage
- Less expensive roof drainage system
- HVAC ducts may be run within truss space