

HOW TO BUILD THE BEST DECK



HIGHLIGHTS:	
Introduction	2
Design tables	4
Guide for developing materials list	6
Construction tips	7
Safety precautions	8
Step-by-step construction techniques	9
Maintenance tips	15
Painting/staining/using water repellent	15

HOW TO BUILD THE BEST DECK

INTRODUCTION

Few home improvements can match a wood deck for usefulness, beauty, and enhanced value to a home. For adults, decks offer outdoor living space for entertaining, sun bathing, and dining. For children, they provide a secure outdoor play area.

A deck is a home improvement project that can be done by a contractor or a capable do-it-yourselfer. Design is straightforward. No advanced carpentry skills or sophisticated tools are needed. If you can hammer a nail, saw on a straight line, and read a level, then building a deck should present no major problems.

What's more, the use of Wolmanized® pressure-treated wood helps assure that your project will provide years of enjoyment.



REASONS TO BUY WOLMANIZED® WOOD

- It's guaranteed for a lifetime against fungal decay and termites. (See lifetime limited warranty certificate for details.)
- It's economical. Wolmanized® wood costs less than such naturally rot-and-decay-resistant species as all heart redwood and cedar, and considerably less than composite decking and tropical hardwoods.
- It's easily stained or painted. Left unstained, it will weather to a rustic gray.
- It's clean, odorless and non-staining.
- It can be sawed, planed, drilled and nailed. Wolmanized® wood has basically the same physical characteristics as ordinary lumber.
- It's proven. Wolmanized® wood has been used effectively and safely for more than 70 years.
- It's wood. Wood is a renewable resource that requires less energy to produce than alternatives, and is less costly and more attractive. Treatment extends the life of wood and reduces the need for replacement lumber.

The tables, plans, and tips in this booklet are based on average conditions and intended for people with basic carpentry skills. Where loads may be heavy, a deck is to be elevated to an uncommon height, soil is unstable, wind or snow is sometimes a problem, or where other unusual conditions may exist, consult someone knowledgeable in deck design and lumber construction for advice.

Although every effort has been made to ensure the accuracy of all details in this pamphlet, the possibility of error in any presentation always exists, so double-check before you begin any project. The originator and distributor of this booklet shall not be responsible for injury, damage, or loss, however caused, resulting from information contained herein.

HOW TO BUILD THE BEST DECK

DECK LUMBER

Wood is a beautiful, natural material. And it's renewable. Properly pressure-treated, wood can last for decades, unharmed by enemies such as termites and decay-causing fungi.

But, treated or untreated, wood can develop surface checks or splits; it may warp; it can twist. Possible problems which may arise from these tendencies can be greatly minimized by following the construction tips found in this booklet.

Wolmanized® wood is available in a variety of lumber quality grades — from top grades for

architectural applications to less attractive grades for hidden or general construction uses.

It is also treated to various preservative retention levels for use above ground and in ground contact.

Ask for the grade and retention suited to your use.

Wolmanized® Outdoor® wood can be treated with a specially formulated water repellent as well as Wolman® preservative. This gives built-in protection against water damage, helping to prevent premature aging, cracking, and warping.

BEFORE YOU START

The location and design of your deck should be influenced by several factors:

- Anticipated use (private sunbathing, large parties, family relaxation, outdoor cooking)
- Air currents (allow flow of gentle breezes, block out prevailing winds)
- Existing structure (should be compatible)
- Sunlight (desire sun or shade?)
- Privacy (screen certain areas, avoid street noise, landscaping)
- View (emphasize a good view, mask a poor one)
- Safety (children or grandchildren, senior citizens)
- Access to home (adjoin kitchen, living room, or bedroom)
- Terrain (elevated deck, ground level, split level)

Once you have decided on the basic size, shape, and location of your deck, check local building codes. You may find that there are restrictions as to height and size within your subdivision or community. A construction permit will probably be needed, but don't apply for one until you've finalized your planning.

HOW TO BUILD THE BEST DECK

DESIGN

Decks consist of six parts: footings, posts, beams, joists, decking, and railings. In planning your deck, you have three basic considerations: function, structural stability, and appearance.

Not all species of wood have the same strength properties. Ask your lumber dealer what species of treated wood are available in your area, then refer to the tables on this page for suitable sizing.

(Note: a 2 x 4 isn't 2" x 4". Actual size of finished dry lumber is given in Table 1.)

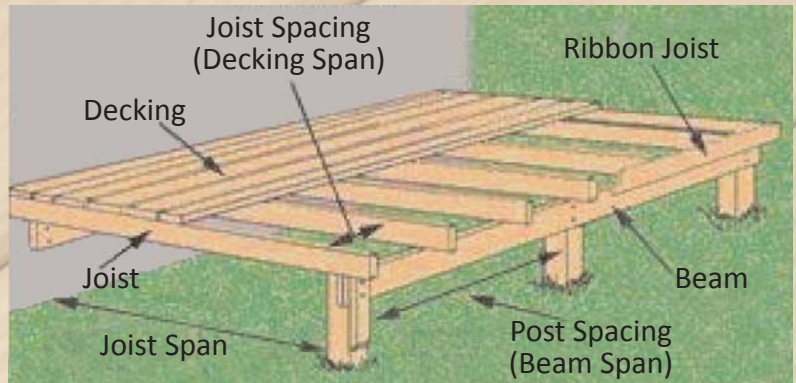

Table 1 –
Lumber dimensions in inches

Nominal	Dry
1 x 6	3/4 x 5 1/2
1 1/4 (5/4) x 6	1 x 5 1/2
2 x 2	1 1/2 x 1 1/2
2 x 4	1 1/2 x 3 1/2
2 x 6	1 1/2 x 5 1/2
2 x 8	1 1/2 x 7 1/4
2 x 10	1 1/2 x 9 1/4
2 x 12	1 1/2 x 11 1/4

Table 2 –
Determining joist size

Based on 12" joist spacing		
Max. Joist Span: Southern Pine Hem-Fir Douglas Fir	Max. Joist Span: Red Pine Ponderosa Pine	Use Joist Size:
9'	7'6"	2 x 6
12'	10'	2 x 8
15'	13'	2 x 10
Based on 16" joist spacing		
Max. Joist Span: Southern Pine Hem-Fir Douglas Fir	Max. Joist Span: Red Pine Ponderosa Pine	Use Joist Size:
8'	6'6"	2 x 6
10'	9'	2 x 8
13'	11'6"	2 x 10
Based on 24" joist spacing		
Max. Joist Span: Southern Pine Hem-Fir Douglas Fir	Max. Joist Span: Red Pine Ponderosa Pine	Use Joist Size:
6'6"	NA	2 x 6
8'6"	7'	2 x 8
11'	9'	2 x 10

HOW TO BUILD THE BEST DECK

Table 3 –
Determining Beam Size/Post Spacing

Species: Southern Pine, Hem-Fir, Douglas Fir		
If joist size is	Use double beam of	Max post spacing
2 x 6	(2) 2 x 6	6'
	(2) 2 x 8	8'
2 x 8	(2) 2 x 8	6'
	(2) 2 x 10	8'
2 x 10	(2) 2 x 10	6'
	(2) 2 x 12	8'
Species: Red Pine & Ponderosa Pine		
If joist size is	Use double beam of	Max post spacing
2 x 6	(2) 2 x 6	5'
	(2) 2 x 8	7'
2 x 8	(2) 2 x 8	5'
	(2) 2 x 10	7'
2 x 10	(2) 2 x 10	5'
	(2) 2 x 12	7'

Table 4 –
Determining Post Size

Species: Southern Pine, Hem-Fir, Douglas Fir					
Post Height	Load Area: sq. ft.				
	48	72	96	120	144
Up to 6'	4 x 4	4 x 4	4 x 4	4 x 4	4 x 4
Up to 8'	4 x 4	4 x 4	4 x 6	4 x 6	4 x 6
Species: Red Pine & Ponderosa Pine					
Post Height	Load Area: sq. ft.				
	48	72	96	120	144
Up to 6'	4 x 4	4 x 4	4 x 4	4 x 6	4 x 6
Up to 8'	4 x 4	4 x 6	4 x 6	6 x 6	6 x 6

Knee bracing should be used for heights of 6'-8'. For heights over eight feet, consult a professional engineer.

These tables are based on a live load of 40 pounds per square foot. If your deck will experience heavier loads, consult an engineer or your lumber dealer for design assistance.

HOW TO BUILD THE BEST DECK

DEVELOPING THE DESIGN AND MATERIALS LIST

Follow the steps below to determine the lumber necessary for your deck. These instructions apply to projects in which the decking runs parallel to the wall of the house.

1. Size of desired deck

- Length along house _____ ft.
- Extension from house _____ ft.

2. Deck boards

- Size desired (most common: $\frac{5}{4}$ x 6, 2 x 4, or 2 x 6) _____ " X _____ "
- With maximum $\frac{1}{4}$ " spacing between deck boards, how many boards will be needed (for estimating, figure on three 2 x 4's or two 2 x 6's per 11" width)? _____
- What is the length of deck boards? _____ ft.

3. Joists

- What is the joist span? _____ ft.
- What size joists are needed (Table 2) _____ " X _____ "
- Length of joists (for most decks will be the same as 1 b) _____ ft.
- Number of joists needed? _____
(Length of deck [1a] minus any decking cantilevers, divided by 16" [1'4"] joist spacing plus 1 [for the initial joist])

4. Beams

- Joist span (repeat of 3a) _____ ft.
- Desired distance between posts _____ ft.
- Beam size necessary (Table 3) _____ " X _____ "
- Number of beams needed _____ ft.
- Length of beams _____ ft.

5. Posts

- Height of deck off ground _____ ft.
- Post spacing (repeat 4b) _____ ft.
- Load area (4a x 5b) _____ sq. ft.
- Post size necessary (Table 4) _____ " X _____ "
- Number of posts needed _____
- Length of posts _____ ft.

A ledger and ribbon joist will also be needed. Fascia boards, railing, benches and steps should be added to your material list according to your design. To save trips to the lumber yard, it is advisable to overestimate your needs. Any excess material can always be used in planter boxes and other amenities.

HOW TO BUILD THE BEST DECK

BUILDING TIPS

Whether you hire a contractor or build your project yourself, note: treated wood will last a long time, therefore so will your workmanship. You'll be happier – and your project will look better – if you take your time and observe the following construction techniques.

- Before you begin nailing, lay out your lumber with the best-looking face exposed. Decide which pieces you want for visible areas, and which pieces for understructure.
- Separate deck boards as follows to allow for expansion and contraction. If heavy and wet, separate boards no more than $\frac{1}{16}$ " as some shrinkage will occur. If light and dry, separate boards about $\frac{1}{8}$ " to allow for swelling.
- Avoid long spans in construction. The greater the distance between supporting points, the more force developed within the wood as it dries. Also avoid designs with long cantilevers unsecured at one end.
- Liberally coat all cut ends, holes, or other intrusions into the wood with a suitable wood preservative product containing a minimum of 0.675% copper as oxine copper (copper-8 or copper-8-quinolinolate), 1% copper as copper naphthenate, or 2% zinc as zinc naphthenate. To validate warranty, use of such preservative is required for hem-fir, Douglas fir, and western hemlock of any dimensions, and for other species with a nominal thickness greater than six inches.
- Orient embedded support columns so only treated ends are in ground contact. Cut ends should face upward.
- Cover upper ends of posts with post caps or cut them at angles to shed water.
- Use enough nails. Skimping doesn't pay. Use two nails across a 2 x 4 and three across a 2 x 6. Drive nails at a slight angle toward each other.
- Fasteners should be hot-dipped galvanized or equally protected material meeting ASTM A 153. Connectors should be made from galvanized steel sheet conforming to ASTM A 653 class G185.
- To reduce splitting, drill a pilot hole about three quarters the diameter of the nail. For dense or brittle wood, grind sharpness from nails or blunt the points by striking them carefully with a hammer. Blunt nails cut through; sharp ones pry apart.
- Use $3\frac{1}{4}$ " nails on nominal two-inch decking. Use two at each joint with 2 x 4s laid flat; use three for 2 x 6s laid flat. 3" nails are recommended for $\frac{5}{4}$ " decking.
- Lumber wider than six inches should not be used as a flat surface. Wide, flat boards are subject to ponding of rain water, which can lead to cupping problems. It is better to use two 2 x 6s than one 2 x 12.
- If a board is bowed, install it with the crown up. Gravity and the weight of people and furniture will flatten it.
- If a board has a slight bend to it, it sometimes can be straightened as it is nailed in place.

HOW TO BUILD THE BEST DECK

SAFETY TIPS

Common Sense Safety Precautions

The following precautions should be taken both when handling the preserved wood and in determining where to use and dispose of it. Many of these precautions also apply to untreated wood and other building materials.

Use Site Precautions

- All sawdust and construction debris should be cleaned up and disposed of after construction.
- Do not use treated wood under circumstances where the preservative may become a component of food or animal feed (e.g., in raised beds place an impervious liner such as heavy polyethylene between treated wood and soil). Examples are mulch from recycled treated wood, cutting boards, counter tops, animal bedding, and structures or containers for storing animal feed or human food.
- Only treated wood that is visibly clean and free of surface residue should be used where contact is likely.
- Do not use treated wood for construction of those portions of beehives which may come into contact with honey.
- Treated wood should not be used where it may come into direct or indirect contact with drinking water, except for uses involving incidental contact such as docks or bridges.

Handling Precautions

- Dispose of treated wood by ordinary trash collection. TREATED WOOD SHOULD NOT BE BURNED in open fires or in stoves, fireplaces, or residential boilers because toxic substances may be produced as part of the smoke and ashes. Treated wood from commercial or industrial use (e.g., construction sites) may be disposed of by complying with local landfill rules or burned in commercial or industrial incinerators or boilers when done in accordance with state and federal regulations.
- Avoid frequent or prolonged inhalation of sawdust from wood, treated or untreated. When sawing, sanding, and machining wood, wear a dust mask. Whenever possible, these operations should be performed outdoors to avoid indoor accumulations or airborne sawdust.
- When power-sawing and machining, wear goggles to protect eyes from flying particles.
- Wear gloves when working with wood. Use proper techniques when lifting. After working with wood, and before eating, drinking, toileting, and use of tobacco products, wash exposed areas thoroughly.
- Because preservatives or sawdust may accumulate on clothes, they should be laundered before reuse. Wash work clothes separately from other household clothing.

HOW TO BUILD THE BEST DECK

STEP-BY-STEP CONSTRUCTION

STEP 1

Mark off the deck area using string and “batterboards” making sure that it is level and square. The string will help you visualize the size and appearance of the finished deck and will also serve as a guide for excavation and post placement.

Squaring with string

1. Attach string to house and batterboards – make sure it's level.
2. Use felt tip marker to mark string 3' from corner in one direction and 4' from corner in other direction.
3. When the diagonal connecting these two points is 5', you have a right triangle and the angle at the corner will be 90°.

Note: To obtain the 5' measurement, move string attached to batterboard to the left or right until correct. To check the accuracy of your layout, compare the corner-to-corner diagonal measurements. They should be the same.

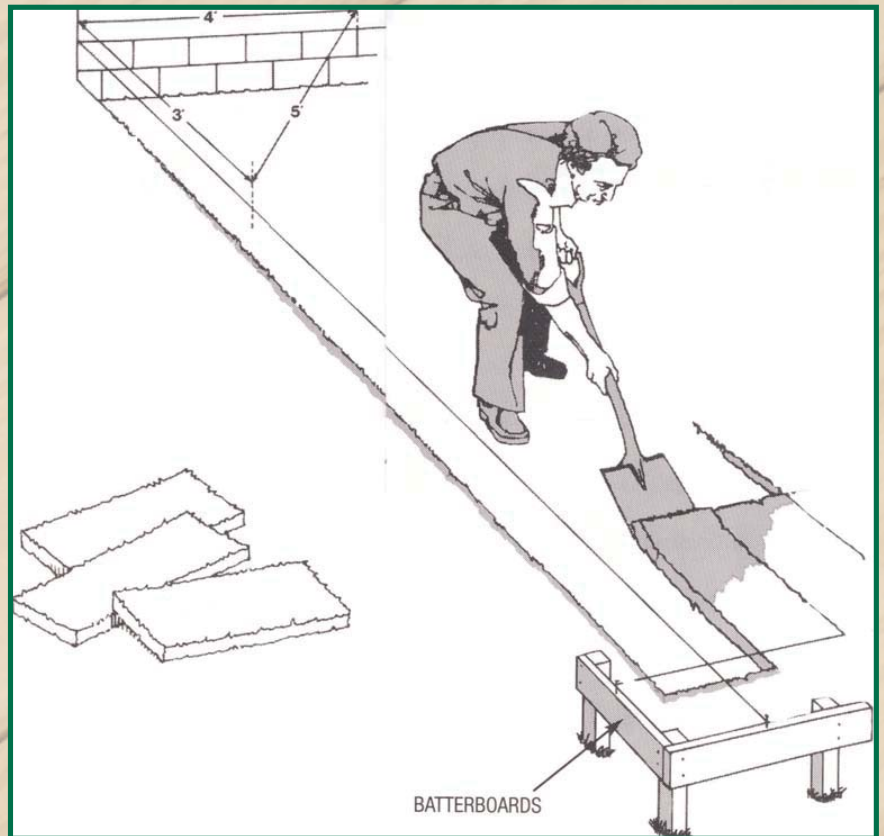

STEP 2

Prepare the site. With a spade or sod cutter, remove sod to a depth of two or three inches. Uncover an area approximately two feet larger than the planned deck. It's unlikely that grass would be able to grow in the shadow of your deck, so you might as well transfer the sod to a bare spot in your yard where it would be useful. To prevent weeds and unwanted vegetation from growing up through the deck, spread a sheet of polyethylene film over the area. You'll have to slit this to embed posts in the ground and to allow for drainage of rainwater. After the posts have been installed, cover the sheet with gravel, pebbles, or bark chips.

HOW TO BUILD THE BEST DECK

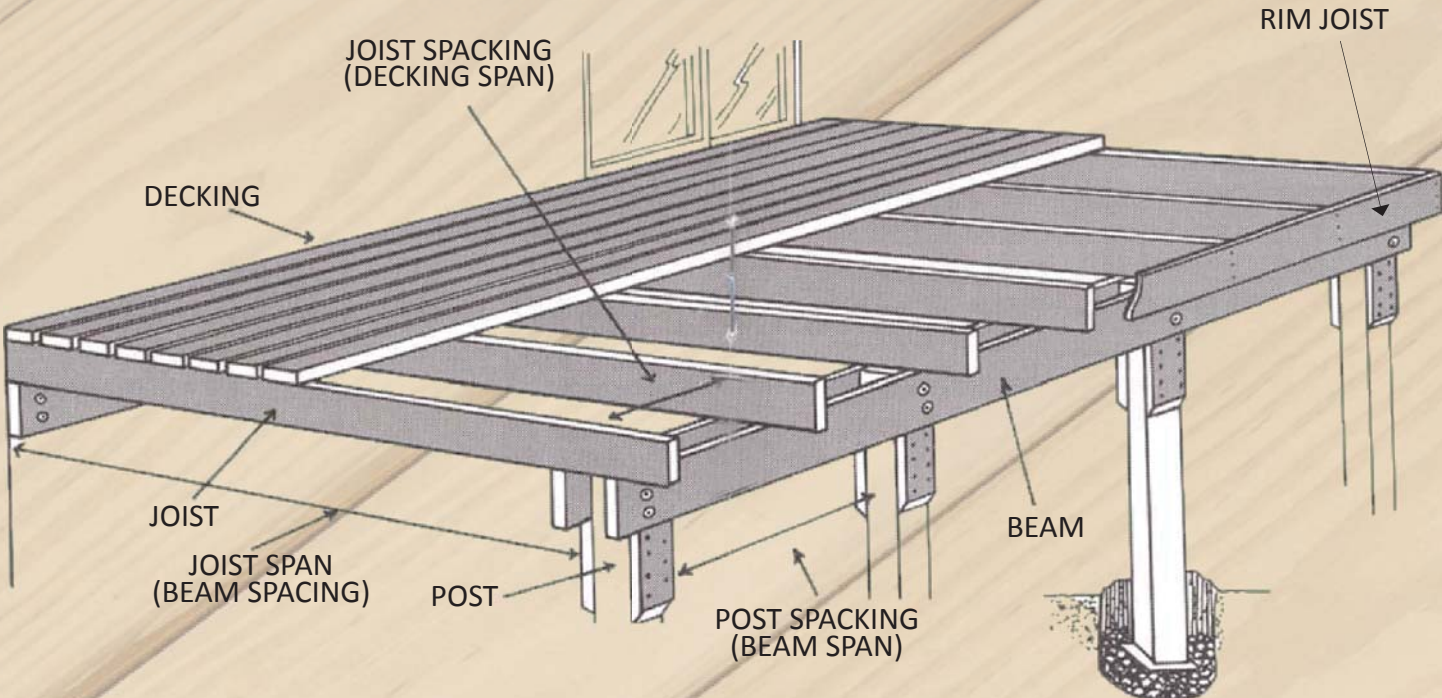

NOTE: Use only untrimmed end of support column in ground contact.

Joist/Beam Size	Maximum Cantilever
2 x 6 or 4 x 6	12"
2 x 8 or 4 x 8	16"
2 x 10 or 4 x 10	18"

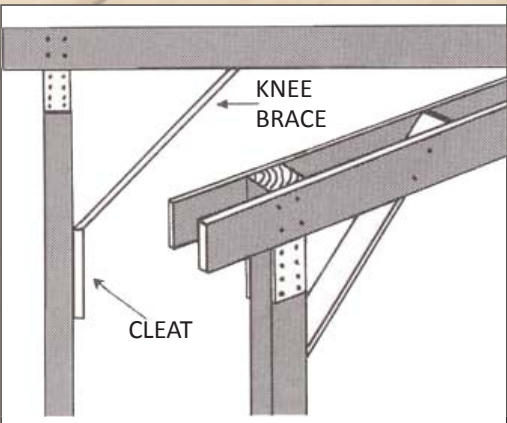

DOUBLE BEAM

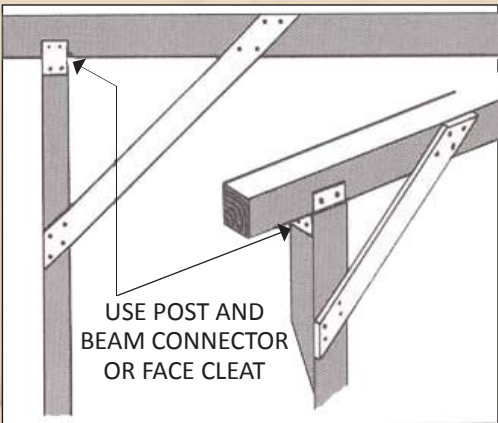

SINGLE BEAM

NOTE: Sway bracing recommended on elevated decks to stabilize platform.

HOW TO BUILD THE BEST DECK

STEP 3

A ledger/header board is the next step if you are attaching your deck to an existing structure.

The placement of the ledger determines the level of the deck floor, so be sure it is positioned at the correct height and is horizontal. In positioning the ledger, don't forget to allow for the thickness of the decking which will be above the ledger level.

Improperly attached ledger boards are a major cause of deck collapses. Anchor it securely to the house. Use bolts, depending on composition of the wall. When fastening ledger boards to wood, the ledger can be held with lag screws. Pre-drill a pilot hole first before driving the lap siding; a strip of the siding can be inverted and used as a shim to hold the ledger perpendicular. Where aluminum or vinyl siding is in place, it is best to carefully cut siding away from house so that ledger/header board can be secured directly to house.

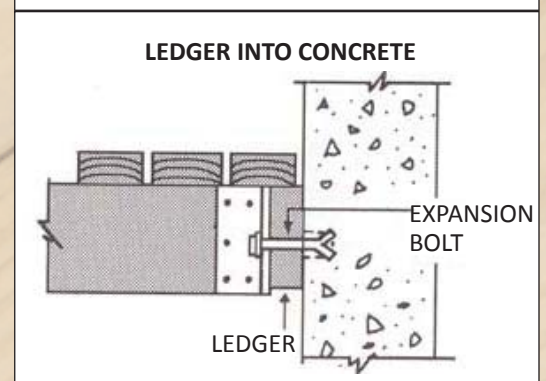
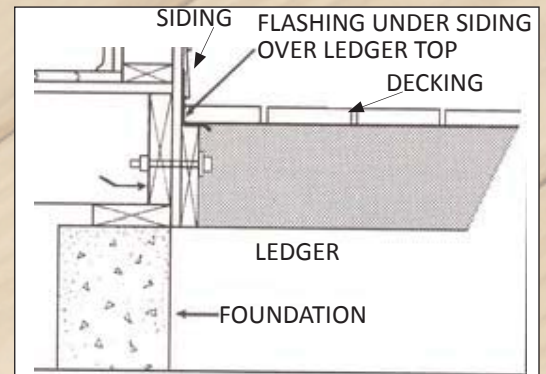

STEP 4

Locate and dig holes for footings. In normal soil the holes should be a minimum of 24 inches deep, although the actual depth will depend on the height of the column and the depth of the frost line. Posts should go deeper than the frost line to avoid heaving during freeze and thaw cycles. Fill the bottom of the hole with gravel and install a Wolmanized® wood plate.

Upright posts can then be positioned on this base. Place only untrimmed ends in ground contact to maximize the preservative protection. Fill the post hole with alternating layers of 4 to 5 inches of gravel and earth. Tamp each layer until hole is filled and post is plumb and solid. Posts can also be set in concrete or attached to a pier. If concrete collars are used, taper the tops downward and away from the post for drainage.

In setting the posts, make sure they are plumb and in alignment with one another. Use a carpenter's level to check for vertical alignment.

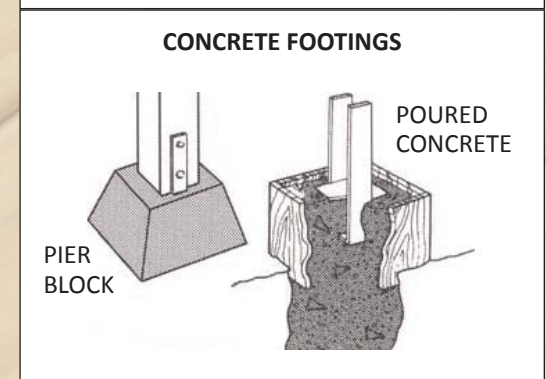
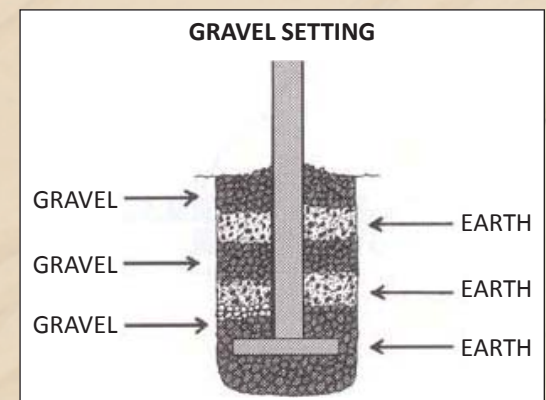

HOW TO BUILD THE BEST DECK

STEP 5

Secure beams to posts. Using a string and level, find the desired deck floor height on the posts. By subtracting the thickness of the deck board and joist (use the actual dimension not the nominal one), you will have determined the correct height for securing the top of the beam to the post. Carefully mark all 4 sides of all posts. You may cut all posts except those serving as railing supports at this time. Fasten the beam to the post, keeping post and beam flush.

Attach joists to the ledger with joist hangers. They must also be attached to the beams and ribbon joist.

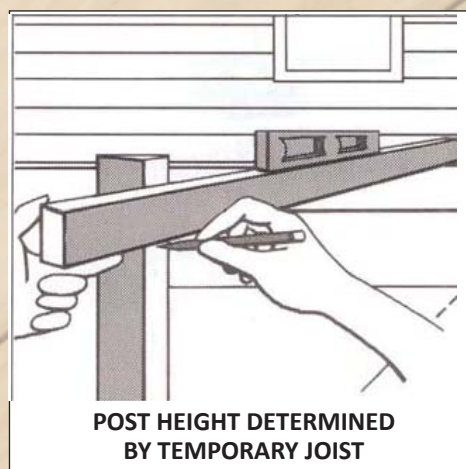
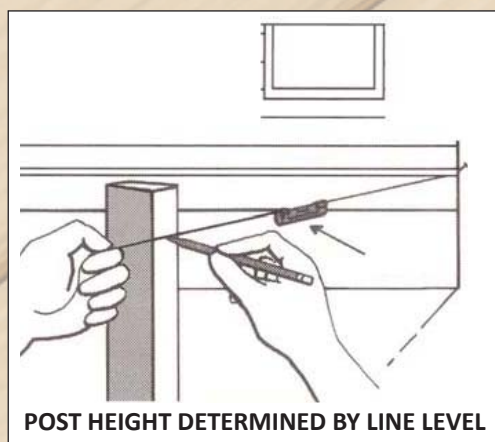

STEP 6

Attach joists. Joists are attached to the ledger with joist hangers. They must also be attached to the beams and ribbon joist.

STEP 7

Install deck boards using hot-dipped zinc-coated nails. You may wish to consider various nail heads and screws; then choose the fasteners with the appearance you like best. If a board is slightly humped, install it with the crown up. The weight of people and objects on the deck, and of the board itself, will tend to flatten it. A curved board can also be used; pry it to the desired position with a chisel and nail securely.

Your deck surface is a visible part of your project. Make it simple with boards of equal width set on joists, or if you prefer, alternate planks of different widths. Make sure you measure as you go; and if you discover your spacing is off, adjust between the next 3 or 4 boards. When you get near the end, start adjusting your spacing to avoid a larger gap.

Trim your deck planks after nailing to assure a straight line. For a finished appearance, cut boards flush to the joist and add fascia.

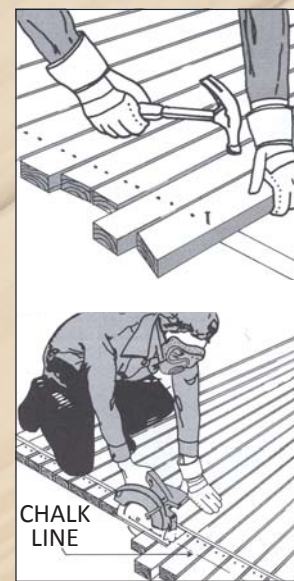

HOW TO BUILD THE BEST DECK

ACCESSORIES

RAILINGS

Install posts for railing. These can be a continuation of the posts which support the deck, or railing posts may be bolted to the outside joist or joist extensions.

Using the deck posts provides sturdy railing support. Intermittent posts, or spacer posts, can be used between the main support posts. Cross members can be nailed to posts at desired height.

The aesthetics of your deck are most obvious in your choice of a railing. Many options are available to you; make sure you choose a design that meets your building codes.

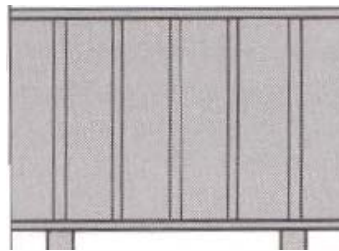

**SINGLE OR V-GROOVED
PLYWOOD**

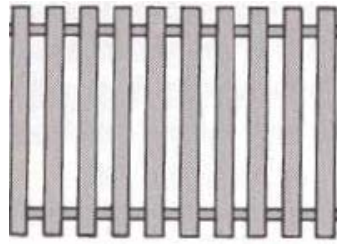

2 X 4s SPACED 4" APART

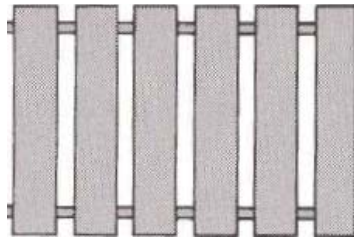

2 X 6s SPACED 2" APART

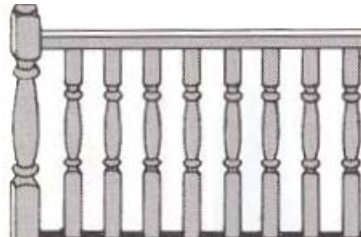

TURNED SPINDLES

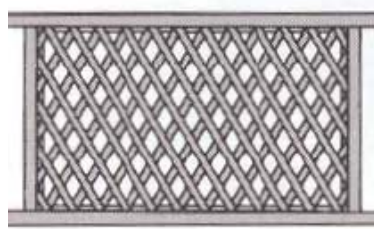

**2' X 4' FRAMED LATTICE
PANEL**

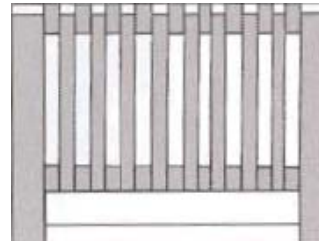

BEVEL-TOP SIDE RAILS

HOW TO BUILD THE BEST DECK

BENCHES

Benches can be free-standing, integrated into railings, or combined with planter boxes. Built-in benches are a very efficient and practical way to provide seating on a deck.

Seats should be at least 15" wide and 15"-18" above the deck floor.

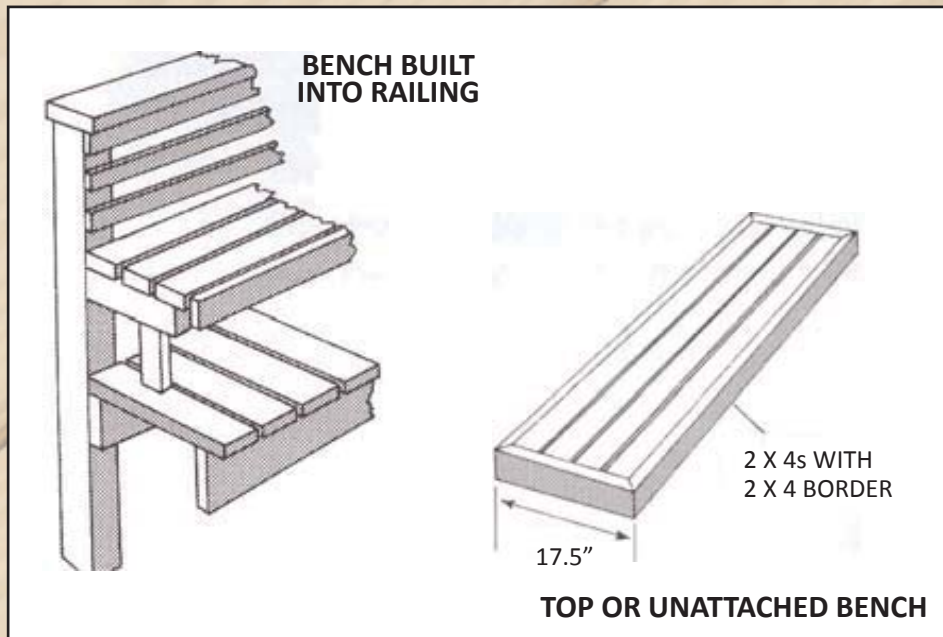

STEPS

Measure the vertical rise and decide upon the best riser size for each step. This will determine the number of steps needed. A recommended riser-to-tread ratio is 7" to 11"; other comfortable ratios include 6"/15.5" and 5"/17". Multiply the number of steps by the tread length to find the overall run of the stairs. Using 2 x 4 or 2 x 6 boards for treads will reduce cupping problems common with wider boards. You may also purchase pre-cut step stringers that eliminate difficult angle-cutting.

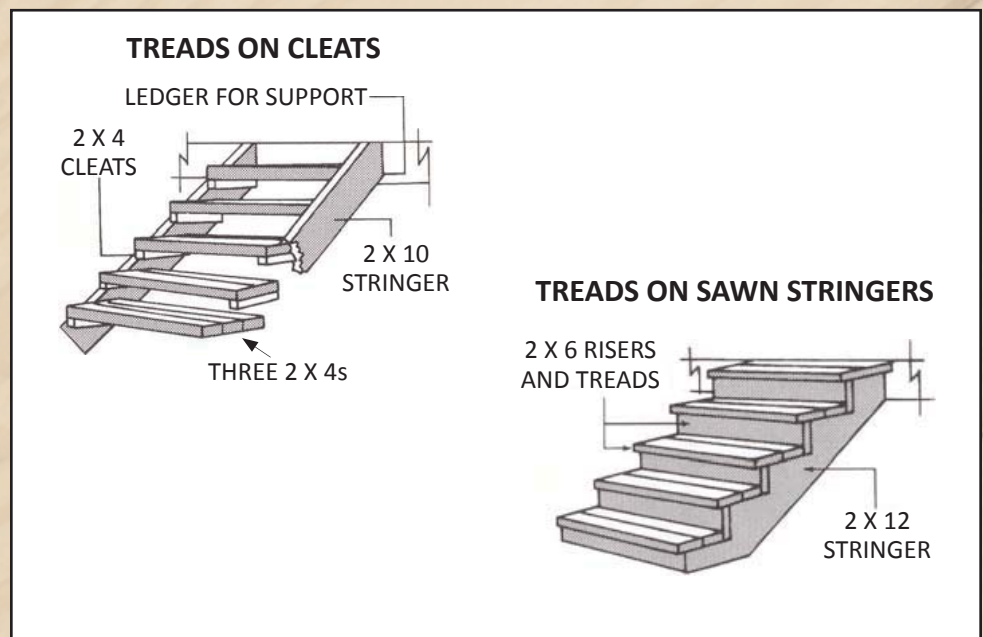

HOW TO BUILD THE BEST DECK

MAINTENANCE TIPS

No maintenance is needed to renew resistance to fungi and termites. Wolmanized® wood has a lifetime limited warranty against these organisms. However, protection is required to maintain the wood's appearance against weather. Sun and rain cycles cause stresses in lumber and result in swelling, shrinking, warping, and cracking.

- To help protect your project against moisture damage, apply an effective brand of surface water

repellent as soon as your outdoor wood project is finished or, for large projects, as sections are completed. Water repellent should be applied every year or two.

- To revitalize a dingy appearance caused by dirt and mildew, use deck brightener to clean the outdoor wood.
- To validate the warranty in some states and for some species, apply an end-cut solution.

PAINTING/STAINING/USING WATER REPELLENT

You can stain or paint Wolmanized® wood. You can also coat this wood with a water repellent; in fact, we highly recommend it. The best way to tackle these jobs depends on the wood you have, its exposure, and the coating you plan to use. Many light-colored latex paints can be used successfully, following brush-application of an oil-based primer. Primer should not be applied by sprayer, nor should coatings be used if their manufacturer advises against a primer. Always follow the manufacturer's directions and take special care in sealing end grain, holes, and other penetrations with the primer.

How long must you wait before the wood is dry internally?

The time it takes for wood to dry out depends on the climate and the wood's exposure. In summer in the American southwest, deck lumber open to sunshine can dry in a few days. In cool, damp weather or when shaded by an overhanging roof or tree, it will take much longer for wood to dry. We offer an estimate of the time required for the wood's moisture level to reach equilibrium with the atmosphere: as a fairly safe average, we recommend waiting six months before applying paint.

For more information, choose the following scenario that best suits your situation.

Are you using: Typical treated wood? Treated wood with built-in water repellent? Treated wood that is re-dried after treatment?

Typical treated wood

When wood is pressure-treated, it is saturated with a liquid solution of preservative diluted in water. In a typical situation, the wood you buy is still somewhat damp.

PAINT — Do not apply paint until the wood is dry, both on the surface and internally. Otherwise, as the wood dries out, escaping moisture will cause blisters and poor adhesion in the paint. We recommend a six-month waiting period before applying paint. Once the wood is dry, the procedure for painting treated wood is no different from that for painting untreated wood. (We recommend against using paint on deck flooring because frequently used pathways, such as from the steps to the door, will become worn.)

NOTE: END CUT SOLUTION. For hem-fir, Douglas fir, western hemlock, and Canadian woods, all cut ends and bore holes should be coated at the time of construction with a suitable wood preservative, such as Outlast® Q³ Log Oil™. This measure is required for validation of the warranty, as is proof of purchase of the preservative.

HOW TO BUILD THE BEST DECK

STAIN — Some stains are heavily pigmented and form a film, just as paint does. The recommendations for their application are the same as those for paint, including our advice against using them for the floor of a deck. Most stains, however, are more transparent and do not block moisture movement. There are other differences, though. Stains may be oil-based or water-based. Some formulations can be used immediately; others perform best when the wood is allowed to dry for a while. Best advice: follow the stain manufacturer's instructions.

WATER REPELLENT — Most water repellent brands say that it is okay to apply a water repellent without delay, which is ideal timing. For other brands, a slight delay is recommended. Again, it is best to follow the manufacturer's instructions.

Treated wood with built-in water repellent

To protect against moisture damage, some Wolmanized® Outdoor® wood has water repellent as well as preservative. The water repellent slows down the rate at which the wood absorbs and releases moisture.

PAINT & STAIN — The recommendations are the same as above, but it may take longer for the wood to dry out. Therefore, the delay may be longer. For instance,

we recommend waiting 30 days before applying an oil-based product to treated wood, and waiting a year before using a water-based stain.

WATER REPELLENT — With water repellent treated wood, an initial coating of topical water repellent is not necessary. For Wolmanized® wood with water repellent, you don't need a water repellent coating for a year, but apply it every year or two thereafter.

Treated wood that is re-dried after treatment

In some areas you can buy treated wood that is Kiln Dried After Treatment (KDAT) or Air Dried After Treatment (ADAT). In these processes, moisture is removed from the wood before shipment to a lumber dealer. KDAT or ADAT will be marked on each piece of wood on either the end tag or an ink stamp.

PAINT, STAIN, WATER REPELLENT — The moisture content of the wood is already in balance with atmospheric moisture levels, so coating can proceed immediately (unless wood contains built-in water repellent — see above).